

D. J. CANCESTER.
LAMP BURNER.
APPLICATION FILED JUNE 28, 1906.

929,752.

Patented Aug. 3, 1909.
2 SHEETS—SHEET 1.

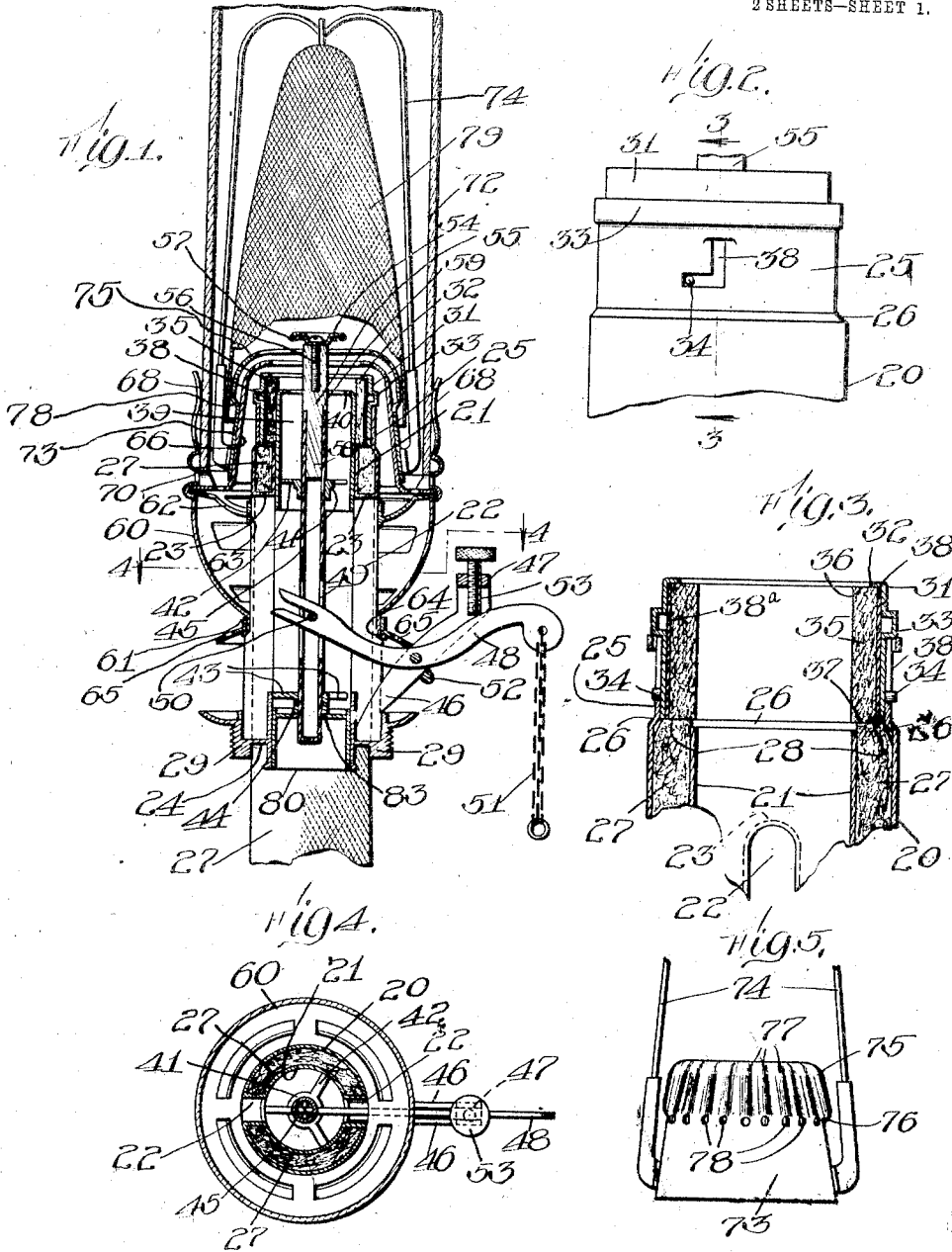

Witnesses:
G. U. Dumas,
J. H. Jochum, Jr.

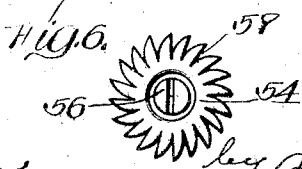

Inventor:
D. J. Cancester
by Brown, Darling & Hopkins
Attys

BEST AVAILABLE COPY

D. J. CANCHESTER.

LAMP BURNER.

APPLICATION FILED JUNE 26, 1906.

929,752.

Patented Aug. 3, 1909.

2 SHEETS—SHEET 2.

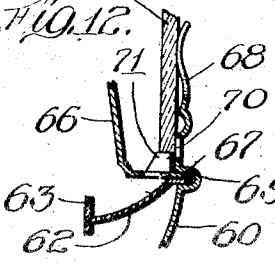
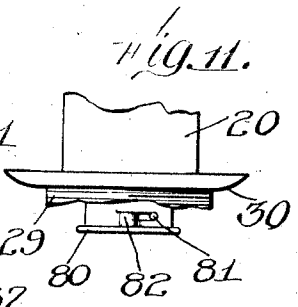
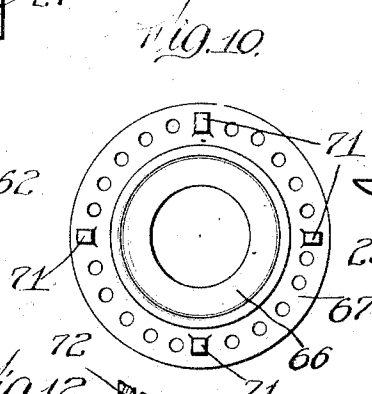
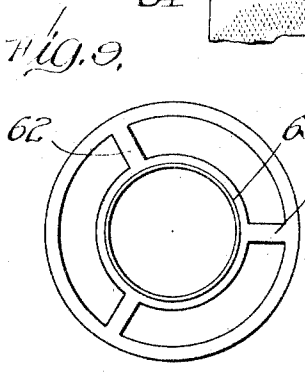
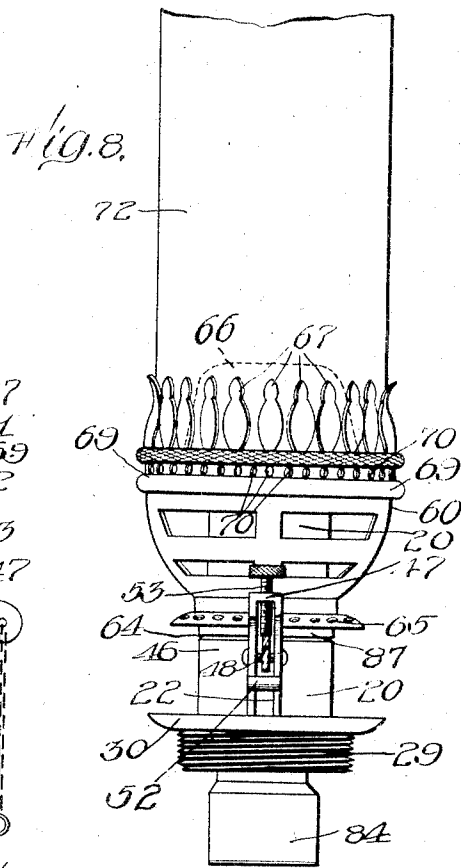
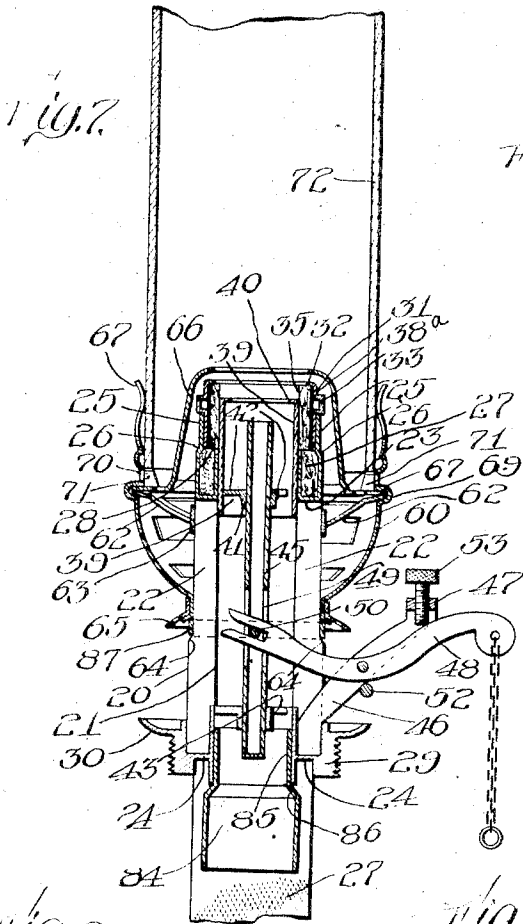

Witnesses:
 C. V. Romarua
 J. N. Jochum, Jr.

Inventor:
 D. J. Canchester
 by Brown & Berkey
 Attys

UNITED STATES PATENT OFFICE.

DAVID J. CANCHESTER, OF CHICAGO, ILLINOIS.

LAMP-BURNER.

No. 929,752.

Specification of Letters Patent.

Patented Aug. 3, 1909.

Application filed June 28, 1906. Serial No. 323,918.

To all whom it may concern:

Be it known that I, DAVID J. CANCHESTER, a citizen of the United States, residing at Chicago, in the county of Cook and State of Illinois, have invented certain new and useful Improvements in Lamp-Burners, of which the following is a full, clear, and exact specification.

This invention relates to improvements in lamp burners and more particularly to that class of burners adapted to vaporize and burn a liquid hydro-carbon for the production of light or heat, and which may be readily applied either to an ordinary or center draft lamp.

A further object is to provide an improved burner which may be used with a mantle for producing an incandescent light, or quickly converted into a burner for producing an argand light.

A further object is to provide improved means for regulating the flame and for supplying air thereto.

A further object is to provide an improved wick.

A further object is to provide an improved lamp of this character which will be simple in construction, cheap to manufacture, and efficient in operation.

To the attainment of these ends and the accomplishment of other new and useful objects as will appear, the invention consists in the features of novelty in the construction, combination and arrangement of the several parts hereinafter more fully described and claimed and shown in the accompanying drawings illustrating the embodiment of this invention; and in which:

Figure 1 is a longitudinal sectional view of a burner constructed in accordance with the principles of this invention, adapted to be used with a mantle. Fig. 2 is an enlarged detail elevation of the upper end of the wick tube. Fig. 3 is a sectional view on line 3-3 of Fig. 2. Fig. 4 is a sectional view on line 4-4 of Fig. 1 looking in the direction of the arrows. Fig. 5 is an enlarged detail view of the base of the mantle support. Fig. 6 is an enlarged plan view of the spreader or gasifier. Fig. 7 is a view similar to Fig. 1 of the burner arranged for burning an argand flame. Fig. 8 is an elevation of Fig. 7. Fig. 9 is a detail view of a portion of the gallery. Fig. 10 is a plan

view of the chimney or support. Fig. 11 is an enlarged detail view of the lower portion of the burner. Fig. 12 is an enlarged detail sectional view of a portion of the gallery and a portion of the chimney in position.

In the drawings, the same reference numerals designate similar parts throughout the several views.

In this exemplification of the invention, the burner consists of two concentrically arranged tubes 20-21, the outer one of which is of a considerably larger diameter than the inner tube to form a wick space therebetween. Both of these tubes are preferably provided with slots which register with each other to form openings 22, which extend from substantially near the top to the base thereof. These tubes are held spaced from each other in any suitable manner, preferably by means of a portion of one of the tubes adjacent the slots being bent toward and in contact with the other tube, to form shoulders or supports 23 at the tops of the slots, and spacing lugs 24 at the bottom of the slots. This arrangement serves as a means for closing the ends of the space between the two tubes adjacent the slots to form a housing for the wick, to protect the same and also to prevent entrance of dust, etc., and at the same time permit sufficient air to pass into the burner tube. The outer tube 20 is somewhat longer than the inner tube 21, to form a projecting portion above the top of the tube 21. This projecting portion is preferably reduced above the end of the tube 21 to form a circumferential shoulder 26 at a point substantially in line with the top of the inner tube 21.

A suitable wick 27 is placed within the space between the tubes 20-21, and said wick is preferably bifurcated, one of the bifurcated portions standing on each side of the slots or apertures 22, and said wick is of sufficient length to project below the bottom of the burner and extend into the basin of the lamp in the ordinary manner. The body of the wick beyond the bifurcated portions is of such a length that the base of the bifurcations will rest upon the shoulders or supports 23 between the tubes 20-21 and the top 28 thereof will engage the shoulder 26 formed by the projecting portion 25, on the tube 20, and project slightly above the top of the inner tube 21, for a purpose to be

set forth. With this arrangement it will be seen that when in position the wick 27 will be completely housed and protected and that by means of the base of the bifurcations resting upon and being engaged by the shoulders or supports 23 it will be impossible for the wick to become displaced or be forced or accidentally drop into the lamp basin. Any suitable wick may be employed such as a tubular wick cut to form the bifurcated portions or a specially prepared wick may be used.

A screw threaded portion 29 may be formed on the outer tube 20, or secured thereto, which serves as a means by which the burner may be attached to the lamp basin. The top 30 thereof is preferably cup shaped to serve as a receptacle to catch any of the oil which may escape from the burner.

A suitable ring or collar 31 is provided with an inwardly projecting portion or flange 32 at its upper end and a laterally projecting circumferential portion or bead 33 located preferably adjacent the flanged end thereof. A supplemental tubular wick 35 is removably and reversibly held within the ring or collar 31 so that the upper edge 36 thereof will engage and rest under the flange 32, and with its bottom terminating substantially flush with the lower edge of the ring or collar. This ring or collar is of such a diameter as to snugly fit within the projecting portion 25 of the tube 20, and is of a length that when the projecting portion or bead 33 thereon rests upon the top of the portion 25, its lower edge and also the edge 37 of the supplemental wick 35, will rest upon and engage the edge 28 of the wick 27, so that the supplemental wick 35 will be supplied with oil by means of capillary attraction, from the wick 27, and the ring or collar may be held or locked from displacement in any suitable manner, preferably by means of pins or lugs 34, projecting from the periphery thereof, which are adapted to enter ordinary bayonet slots or grooves 38 in the portion 25. If desired, any suitable material 38^a, such as paper or the like may be secured to the periphery of the supplemental wick 35, for preserving and causing the same to maintain its shape. Thus it will be seen that when it is desired to remove the supplemental wick 35, the ring or collar 31 is first removed from the portion 25 of the tube 20, after which the wick may be easily slipped out of the collar or ring.

Sliding within the inner tube 21 of the burner and of a diameter to contact with said tube is a hollow tubular regulator member 39, the upper end of which may be flanged inward as at 40 if desired. This member is provided with a web comprising a body 41 supported by spaced arms 42, and adjacent the base of the burner, but remote

from the end thereof is a similar web 43 provided with a bearing 44. Passing through the body portion 41 of the web and secured thereto is a tube 45, the upper extremity of which is preferably above the web and adjacent the top of the tubular regulator member 39, and said tube moves with the member 39. The lower end of the tube passes through the bearing 44 in the web 43 and is of a length to prevent the end thereof from disengaging the web 43 when the tubular member is at its extreme highest point. This member 45 is preferably hollow for the sake of lightness and closed at its lower end to prevent anything from passing therethrough and into the lamp basin. Thus it will be seen that when the tubular member 39 is raised or lowered the member 45 will serve as a guide to prevent displacement and to maintain said member 39 in proper position. Any suitable means may be employed for raising and lowering the tubular or regulator member. A simple and efficient means for accomplishing this purpose, which will now be described, comprises spaced arms 46 secured to the burner and are preferably connected at their top as at 47. An arm or lever 48 is pivoted between the arms at a point intermediate its own length, and one end thereof projects through one of the slots 22 in the burner with its extremity standing within a slot 49 in the tubular guide member 45. The extremity of the arm or lever 48 is bifurcated so as to loosely receive a transverse pin or bar 50 extending across the slot 49. The other end of the arm or lever may project for any suitable distance beyond its pivot point and attached thereto is a flexible or operating member 51. The weight of the regulator and guide members is sufficient to hold the free end of the arm or lever 48 elevated. Thus when the flexible or operating member 51 depresses the free end of the arm or lever the regulator member 39 will be raised and when released will drop back to its normal position. In order to prevent the regulator and guide members from being thrown out of position by depressing the free end of the arm or lever too far, a suitably located stop 52 may be arranged within the path of movement of the arm or lever 48, the rotary or axial movement of these members being prevented by the bifurcated end of the arm or lever 48, standing within the slot 49 of the guide member 45. The arm or lever 48 may also be operated by means of a regulating or adjusting screw 53 which passes through the connecting portion 47 of the arms 46 and is adapted to engage and depress the free end of the arm.

A suitable spreader or gasifier 54 is removably secured to one end of a stem 55 in any desired manner such as by means of a screw or bolt 56. The periphery of this

5 spreader or gasifier is notched to form wings
 57 which are bent at an angle to the body
 portion 54, and to a position to slightly
 overlap each other and to direct the flame
 10 outward. The stem 55 is provided with a
 reduced portion 58 to form a shoulder 59,
 the diameter of the reduced portion 58 be-
 ing of such a size as to enter and fit within
 the upper end of the tubular or guide mem-
 15 ber 45, so that the shoulder 59 will rest upon
 the edge thereof. This shoulder 59 is
 located at such a point that the spreader or
 gasifier will be properly spaced from the
 top of the regulator member 39.

15 The gallery comprises a perforated base
 or body portion 60 which is preferably con-
 structed in the form of a basket contracted
 at its lower end, as at 61 and adjacent its
 upper end is provided with arms 62, sup-
 20 porting a centrally disposed ring or collar
 63, of the same diameter, and which is ar-
 ranged to register with the contracted por-
 tion 61, and these registering portions are
 adapted to receive the end of the burner.
 25 The contracted portion 61 being adapted to
 engage and rest upon a suitable shoulder 64
 formed on the burner, and serves as a means
 for supporting the gallery. The lower ex-
 30 tremity of the body portion is preferably
 flanged outward to serve as a base upon
 which the gallery rests when removed from
 the burner. It also serves as a shield from
 the flame when replacing the gallery on the
 tube.

35 A conical burner shield or hood 66 is pro-
 vided with a lateral projecting perforated
 flange or base 67. The extremity of the
 arms 62 and the periphery of the base or
 flange 67 being adapted to be secured to the
 40 body 60 at a point adjacent the chimney
 holders 68 in any desired manner, preferably
 by means of flanging or crimping the body
 portion over the edges thereof as shown at
 45 69. The top of the shield or hood 66 is
 disposed to stand adjacent to and slightly
 above the top of the supplemental wick 35,
 and the body thereof is so spaced from the
 burner tube that air will be drawn between
 50 the shield or hood and the burner, and be
 directed against the flame. The body por-
 tion 60 of the gallery is provided with a
 series of perforations 70 above and adjacent
 the flanged base 67 of the hood or shield 66,
 and the latter is provided with spaced up-
 55 wardly projecting portions or lugs 71 upon
 which the chimney or globe 72 rests, as more
 clearly shown in Fig. 12. Thus it will be
 seen that additional air will be permitted to
 enter the perforations 70 and pass beneath
 60 and into the chimney or globe 72.

A suitable mantle support is provided
 with a conical base 73 to which the extremi-
 ties of the mantle supporting arms or wires
 74 are secured. The upper portion of this
 65 base is enlarged as at 75 to form a shoulder

76, and said enlarged portion is provided
 with corrugations 77 arranged longitudi-
 nally thereof and said corrugations extend
 from one shoulder and terminate short of
 the top of the enlarged portions. Passing 70
 through the shouldered portion 76 are a
 plurality of apertures or holes 78 one of
 which is preferably arranged adjacent the
 end of each of the corrugations. The base
 of this mantle support is adapted to be 75
 passed over the burner shield or hood 66, so
 as to rest upon the flange 67 and with the
 portion 73 engaging said hood or shield.
 The enlarged portion 75 stands adjacent and
 projects slightly above the hood or shield to 80
 form a space therebetween, into which air
 passes through the openings or apertures 78
 and is directed against the flame. The
 lower extremity of the mantle 79 rests
 against the periphery of the corrugated por- 85
 tion and extends across the corrugations
 therein in such a manner as to permit air to
 enter between the periphery of the corru-
 gated portion and the mantle 79. With
 such an arrangement sufficient air will be 90
 directed against the spreader or gasifier and
 by this manner of admitting the air together
 with its contact with the heated parts, the
 air will become superheated, thereby insur- 95
 ing perfect combustion and preventing carbon-
 ization of the mantle. If the mantle should
 not be perfectly straight or if for any other
 reason the flame should make one side of
 the mantle more incandescent than the other
 then the weaker side would naturally carbon- 100
 ize a little. With this arrangement and
 in order to overcome this difficulty, the com-
 plete gallery may be rotated about the
 burner and upon the supporting shoulder
 64, to bring the carbonized portion in proper 105
 position so that the flame which will burn
 the carbon off.

When it is desired to use this improved
 burner with a lamp which is not a center
 draft lamp, the lower end of the inner tube 110
 21 of the burner may be closed in any de-
 sired manner, but preferably by means of a
 cap or plug 80 fitting therein which may
 be secured in any desired manner but pref-
 115 erably by means of an inter-engaging lug
 81 and slot 82 forming the ordinary bayonet
 joint (see Fig. 11). This cap or plug may
 be provided with the necessary aperture 83
 for the end of the guide or tubular member
 45 to pass through. When using the same 120
 with a center draft lamp the plug or cap
 80 is removed and a member or nozzle 84
 having a reduced portion 85 to form a
 shoulder 86 may be used, or any other con-
 nection or coupling suitable for the purpose 125
 may be employed. In this exemplification
 the body portion of the member is applied
 over the end of the central air supply tube
 and held in any desired manner and the re-
 130 duced portion 85 is inserted into the lower

end of the inner tube 21 of the burner so that the end thereof will rest upon and be supported by the shoulder 86.

The exemplification shown in Fig. 1 is employed with a mantle for producing an incandescent light, the air entering and being directed by the various passages against the spreader or gasifier 54. The vapor being ignited and burned adjacent the inner face of the supplemental wick 35 at the top thereof and is deflected or spread by the plate 54 uniformly against the inside of the mantle. The flame being regulated by means of the sliding regulator 39, operated by the arm or lever 48. When it is desired to extinguish the flame the regulator is thrown suddenly upward so that the upper end thereof will project above the upper end of the supplemental wick 35 which will cut out the flame. In this form of the invention the supplemental wick 35 does not burn but only the fuel burns, which is vaporized or gasified adjacent the face of the wick.

When it is desired to use the burner as an Argand burner the mantle and support, together with the spreader plate or gasifier 54 are removed. With this form of burner it is necessary to reduce the pressure of the air which is supplied to the burner. This may be accomplished if the gallery is raised to space the hood or shield 65 farther from the end of the supplemental wick 35.

Any suitable means may be employed for supporting the gallery in its raised position, but a simple and efficient means for this purpose comprises a ring or collar 87, which surrounds the burner and rests upon the shoulder 64, and upon which the gallery rests. To apply this ring the gallery is removed from the burner, the ring 87 slipped over the end of the burner and against the shoulder 64, and the gallery then replaced. The operation of the parts are the same in this exemplification with the exception that instead of vaporizing the oil and burning the vapor, the supplemental wick 35, is itself burned but is supplied with oil from the main wick 27 in the same manner. The same result may be accomplished if the chimney is raised so that the openings 70 in the holder will not be restricted.

In order that the invention might be fully understood, the details of an embodiment thereof have been thus specifically described; but

What I claim is:—

1. In a burner the combination of a tubular wick holder, a stationary tubular wick supported thereby, a supplemental tubular wick, means for holding said supplemental wick, means for removably securing the last said means to the holder, with one end of the supplemental wick engaging the stationary wick, means for directing a supply of air to the other end of the supplemental wick to

support combustion adjacent the inner face at the upper end thereof, and a regulator for the flame, supported within the wicks and movable adjacent the inner face of the supplemental wick.

2. In a burner the combination of a tubular wick holder, a stationary tubular main wick supported thereby, a ring, a supplemental tubular wick removably engaging the ring, inter-engaging means on the holder and ring for removably securing said ring to the holder, one end of the supplemental wick engaging the end of the main wick, means for supplying and directing a supply of air to the end of the supplemental wick to support combustion, and a regulator movable adjacent the inner face of the supplemental wick.

3. In a burner the combination of a tubular wick holder, a stationary wick supported thereby, the upper end of said wick terminating short of the upper end of the holder, a reversible supplemental tubular wick, a holder for said wick, said holder being adapted to be inserted within the upper end of the first said holder with one end of the supplemental wick engaging the upper end of the stationary wick, means for securing said supplemental wick holder to the first said holder in either position of the wick, and means for supplying and directing a supply of air to the top of said supplemental wick.

4. In a burner the combination of a tubular wick holder, a stationary wick supported thereby, the upper end of said wick terminating short of the upper end of the holder, a supplemental tubular wick, a holder for said wick, said holder being adapted to be inserted within the upper end of the first holder with one end of the supplemental wick engaging the upper end of the stationary wick, means for securing said supplemental wick holder to the first said holder, means for supplying and directing a supply of air to the top of said supplemental wick to support combustion and means movable with relation to the supplemental wick for regulating the flame.

5. In a burner the combination of a tubular wick holder, a stationary wick supported thereby, a supplemental tubular wick supported adjacent and in contact with the end of the stationary wick, a tubular regulator movable within the wicks, a centrally disposed support within the regulator, a spreader plate removably supported thereby, spaced from the top of the regulator and above the top of the supplemental wick, said spreader comprising a plate having its periphery notched to form wings and said wings being bent at an angle to the body portion, means for supplying and directing air to the top of the supplemental wick and below the spreader plate, and means for ad-

justing the regulator and spreader, with relation to the top of the supplemental wick.

6. In a burner, the combination of a tubular wick holder, a wick supported thereby, means for directing air to the end of the wick to support combustion, a mantle, a spreader, said mantle and spreader being separate from the first said means and adapted to be removed from the burner, and means for adjusting the first said means with respect to the wick to vary the pressure of the air supplied to the burner for producing an argand flame.

7. In a burner the combination of a wick holder, a wick supported thereby, a gallery, an open hood surrounding the end of the wick holder and supported by the gallery, means for supplying air between the holder and hood to the end of the wick, said gallery and hood surrounding the wick holder and adapted to be raised on said holder for spacing the end of the hood above the wick, a shoulder on the holder, and a removable ring surrounding the holder and resting against the shoulder, said gallery being adapted to rest upon the ring for spacing the hood in its elevated position.

8. In a burner the combination of a wick holder, a wick supported thereby, a spreader, an open hood for the end of the burner adapted to supply and direct air between the end of the burner and the spreader, a mantle support, containing a base separate from and removably surrounding the hood, a portion of said base being spaced from the hood to form an air space between the hood and base, means for supplying air to said space and means for supplying air on the outside of said base.

9. In a burner the combination of a wick holder, a wick supported thereby, a spreader, an open hood for the end of the burner adapted to supply and direct air between the end of the burner and the spreader, a mantle support containing a base separate from and removably surrounding the hood, a portion of said base adjacent the top of the hood

being enlarged and corrugated to form an air space between the top of the hood and said enlarged portion for superheating the air and means for supplying air to the space, said corrugated portions being adapted to permit a supply of air to the outside of the base.

10. In a burner, the combination of a wick holder, a wick supported thereby, an open shield spaced from and surrounding the end of the wick holder, one end of the shield being located in proximity to the end of the wick holder, means for supplying air to the space formed between the wick holder and shield, said shield being mounted for longitudinal adjustment upon its support and into different operative positions with respect to the end of the wick holder to vary the air pressure at the end of the wick holder, and separate means for holding the parts in their adjusted position.

11. In a burner, the combination of a wick holder, a wick supported thereby, an open shield spaced from and surrounding the end of the wick holder, one end of the shield being located in proximity to the end of the wick holder, means for supplying air to the space formed between the wick holder and shield, said shield being longitudinally adjustable with relation to the wick holder into different operative positions to vary the position of the adjacent end of the shield with relation to the end of the wick holder to vary the air pressure at the end of the wick holder and means for holding the shield in any of its various positions said shield being also rotatable about the wick holder in any of its adjusted positions.

In testimony whereof I have signed my name to this specification, in the presence of two subscribing witnesses, on this 22nd day of June A. D. 1906.

DAVID J. CANCHESTER.

Witnesses:

J. H. JOCHUM, Jr.,
CHAS. H. SEEM.